



WINDOBSERVER IS

Intrinsically safe anemometer. Precision wind measurement for hazardous areas

PRODUCT OVERVIEW

WindObserver IS is designed to provide high accuracy wind speed and direction measurement in hazardous environments. WindObserver IS is certified as 'intrinsically safe' for use in the 'hazardous area', whilst the associated power and communications interface is located in the 'non-hazardous area'.

The ATEX, IECEx & UKEX certification ensures that the wind system may be deployed over a large geographical area.

Customer selectable vector rolling average and 3 second gust in accordance with WMO guidelines.

KEY FEATURES & BENEFITS

- 01** Intrinsically safe: ATEX, IECEx & UKEX certification.
- 02** Low voltage or optional mains power supply.
- 03** Galvanic isolation.
- 04** ASCII or NMEA serial output.
- 05** 0-75m/s wind speed operation.
- 06** Averaging/gusts to WMO guidelines.
- 07** Reduced offshore maintenance costs.
- 08** Easy to install and long operational life.

TYPICAL APPLICATIONS

- Offshore oil production and drilling platforms.
- Support tankers.
- Onshore petrochemical plants.
- Helidecks in hazardous environments.
- Paint spray booths.

WindObserver IS is designed for use in potentially explosive atmospheres.



WINDOBSERVER IS

Intrinsically safe anemometer. Precision wind measurement for hazardous areas

TECHNICAL SPECIFICATION

Wind Speed	
Range	0 - 75 m/s (0-168mph)
Accuracy	<2% RMSE @ 12m/s
Resolution	0.01 m/s
Starting threshold	0.01 m/s
Offset	±0.01 m/s
Wind Direction	
Range	0 - 360°
Accuracy	<4° RMSE @ 12m/s
Resolution	1°
Dead band direction	none
Measurement	
Output rate	1Hz, 2Hz or 4Hz
Parameters	UV and polar
Units	m/s, knots, mph, kph, ft/min
Average (selectable)	Rolling average - 1, 2, 10 m.n, Gust - 3s
Block average	0-3600s
Digital output	
Communication	RS422, full duplex to LVPCI
Baud rates	1200, 2400, 4800, 9600, 19200
Formats	8 bit data; odd, even or no parity
Anemometer status	Supplied as part of standard Gill message (NMEA output includes V and A codes as part of the message)
Accessories	
Software	WindView software for displaying data*

WindObserverIS



Power supply	
Anemometer only	6-12 VDC, 30mA peak (from LVPCI) all circuits protected to 0.8 joules
Mechanical	
External construction	Stainless steel 316
Size	380mm x 210mm
Weight	1.9kg
Environmental	
Protection class	IP66 (NEMA4X)
Humidity	0% to 100% RH
Operating temperature	-30°C to +70°C
Precipitation	300mm/hr
Storage temperature	-50°C to +75°C
Approvals	
Intrinsic safety	ATEX, IECEx & UKEX certification. Certificates available to view in full on gillinstruments.com
Operational	
Warranty	24 months
Factory calibration	Traceable to National Standards

WINDOBSERVER IS

Intrinsically safe anemometer. Precision wind measurement for hazardous areas

Hazardous area



WindObserver IS
Intrinsically safe ultrasonic anemometer

ATEX and IECEx certification is valid for systems that include the WindObserver IS with a Gill Power & Communications Interface only.

Non-hazardous area



Low Voltage (DC)
Power & Communications Interface (LVPCI)

(Mains power adaptor option also available - see page 5)

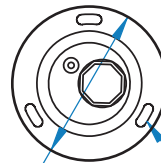

Ø 100mm

3 off slotted fixing holes for M6 or 1/4" screws 120° apart on a PCD of Ø 85mm

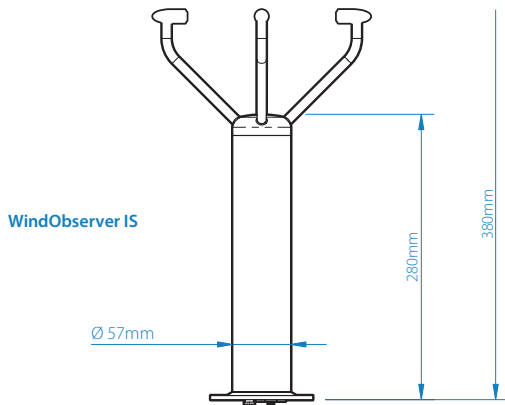

EExe rated junction box (customer supply)

3 long 3 pair screened Ø 8.8mm cable supplied for test purposes only

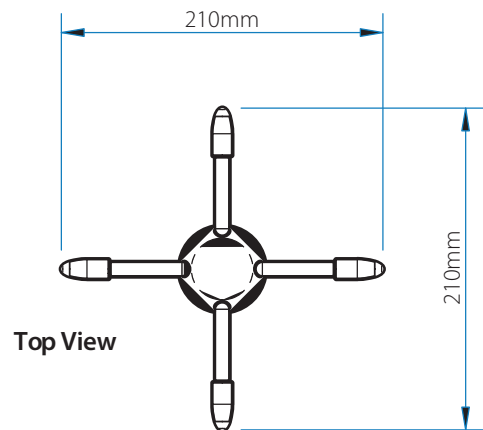

Designed and manufactured in the UK by Gill Instruments Limited.



1954-004 Issue 12
© 2026 Gill Instruments
gillinstruments.com

MORE INFO

For more information about Gill's WindObserver range, please email contact.gi@gill.group

WINDOBSERVER IS

Intrinsically safe anemometer. Precision wind measurement for hazardous areas

Low Voltage Power & Communications Interface (LVPCI) for use in non-hazardous areas

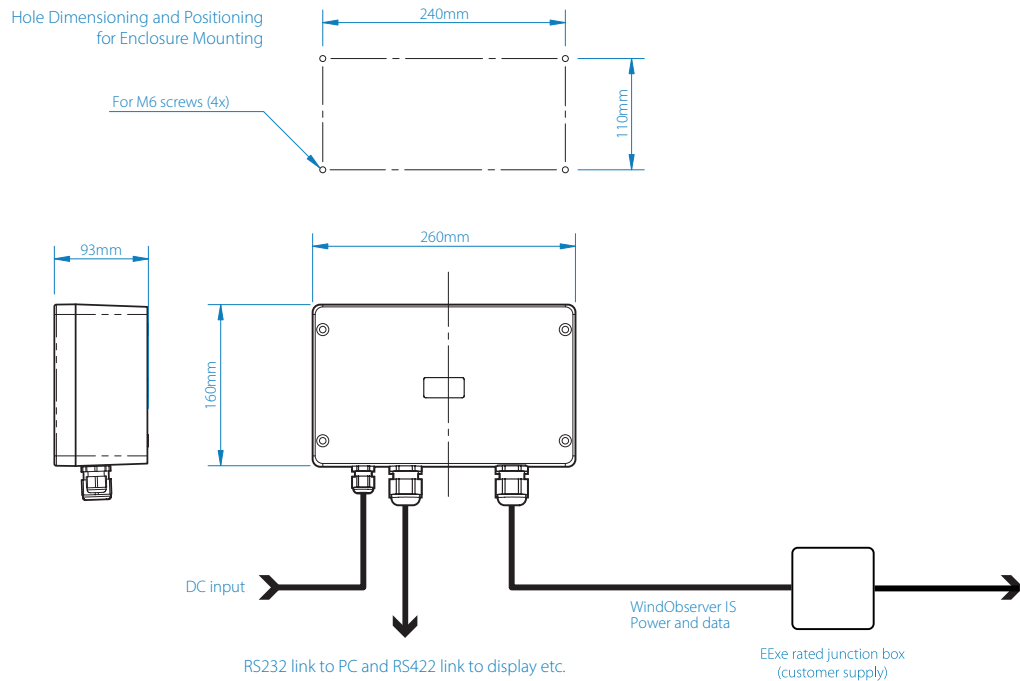

Inputs & Outputs

Digital input	RS422 (data from WindObserver IS to LVPCI)
	Data lines between the anemometer and power supply opto-isolated and protected with zener barriers
Digital output	RS232 and RS422 (data from LVPCI)

Inputs power input

Power requirement	DC supply
Input power	9-30 VDC at 200 mA max
	Galvanic isolation between input power and WindObserver IS
	No external earth required
Output power	10.5 VDC at 50 mA to WindObserver IS (fused 100 mA)

Mechanical

External construction	Fibox Euronord polyester
Weight	2.4 kg
Size	260 x 160 x 93mm
	Refer to additional information drawing on datasheet or manual

Environmental

Moisture protection	IP54
Operating temperature	-30°C to +60°C
Storage temperature	-50°C to +75°C
Humidity	5% to 90% RH
EMC	EN 61326-2-1:2013, EN 61204-3:2000, EN 60945:2002 clause 9 & 10

Certifications & Approvals

Intrinsic safety	ATEX, IECEx & UKEX certification. Certificates available to view in full on gillinstruments.com
------------------	--



1954-004 Issue 12
© 2026 Gill Instruments
gillinstruments.com

MORE INFO

For more information about Gill's WindObserver range, please email contact.gi@gill.group

WINDOBSERVER IS

Intrinsically safe anemometer. Precision wind measurement for hazardous areas

Mains Power Adaptor (5319-10-005) Technical Specification

Power Requirement

Input voltage	90-264 VAC
Output voltage	75 mW
Unit power consumption (no load input power)	75 mW
Input power over voltage protection limit	not present
Input power reverse-polarity protection limit	N/A
Input power protection	internal T1.0A/250 VAC fuse

Mechanical

Moisture protection	IP20
Operating temperature	0°C to +60°C
Storage temperature	-40°C to +85°C
Humidity	5% to 95% RH
Humidity	EN 61000-6-3:2007 EN 61000-6-1:2007

WindObserverIS



1954-004 Issue 12
© 2026 Gill Instruments
gillinstruments.com

MORE INFO

For more information about Gill's WindObserver range, please email contact.gi@gill.group